

USER INSTRUCTION MANUAL
EDGE PARAPET ANCHOR

THESE INSTRUCTIONS APPLY TO THE FOLLOWING MODEL:

AFA930101

CE 0598
EN 795:2012 Type B

Please read and understand the manufacturer's instructions for each component or part of the complete system. Manufacturer's instructions must be followed for proper use, care, and maintenance of this product. These instructions must be retained and be kept available for the user's reference at all times. Alterations or misuse of this product, or failure to follow instructions, may result in serious injury or death.

Note: The user is advised to keep this user instructions document for the life of the product.

- 1. INTRODUCTION:** The Edge Parapet Anchor is classed as a Personal Protective Equipment (PPE) by the European PPE Regulation (EU)2016/425 and have been shown to comply with this Regulation through the Harmonized European Standard EN 795:2012 Type B. This Anchor is designed to minimize the risk of/provide protection against the danger of falling from heights. However, always remember that no item of PPE can provide full protection and care must always be taken while carrying out the risk related activity.
- 2. PERFORMANCE AND LIMITATIONS OF USE:** The Anchor has been tested in accordance with EN 795 : 2012 Type B and has achieved the following performance levels:

EN 795:2012 Type B test	Result/Comment
General Requirements for Anchor devices (Clause 4.2)	(PASS) No sharp edges (PASS).
Static Strength (Clause 4.4.2.3)	Sustained a force of 12 kN for 3 minutes (PASS).
Dynamic Strength & Integrity Test (Clause 4.4.2.2)	When tested with rigid steel mass of 100 kg, the test mass held after test with the device remaining stable throughout. (PASS). Anchor Holds an increased load of 300kg for 3 min following dynamic test.
Corrosion Resistance (Clause 4.7) (EN 364:1992)	No corrosion evident after 48 hours of salt spray testing. (PASS)

- 3. APPLICATION:** The Edge Parapet Anchor is a mobile anchorage connector designed for Parapets and Facades. It has been developed to be used in locations where a low parapet wall provides an anchor point. Suitable for installing on parapets ranging from 60mm to 360mm in width. This anchor provides a safe anchorage point on Parapets and facades for use on various structures.

- 4. INSPECTION:** Visually inspect the system before each use to ensure that it is in a serviceable condition and is operating correctly. If during inspection, doubts are raised about the safety of the system or a component, these should be replaced either by the manufacturer or a competent person.

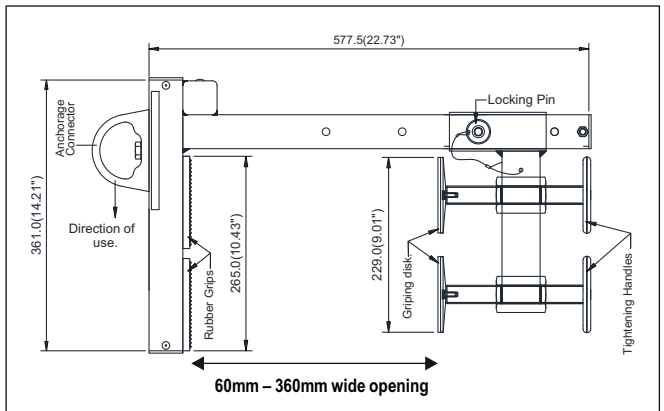

The recommendation that the anchor device be marked with the date of the last or next inspection.

- 5. PRECAUTIONS:**
 - The Edge Parapet Anchor is a piece of personal protection equipment, it should be allocated to a single user (it can only be used by one person at a time). It is a temporary and transportable anchorage point; it is aimed to be used in places where a low wall is a proper anchoring structure. It has to be installed on a wall whose minimum thickness is 6 cm and maximum is 36 cm. Walls must have a resistance which can be able to support static loads applied in the direction of use of 22kN for a user.

- Ensure the Medical condition of the user does not affect his safety in normal and emergency use.
- The equipment shall only be used by a person trained and competent in its safe use.
- A rescue plan shall be in place to deal with any emergencies that could arise during the work.
- Ensure that the anchor is installed directly above the user's head.
- Ensure that the equipment is compatible with other items when assembled into a system.
- It is essential to verify free space required beneath the user at work place before each occasion of use so that in case of a fall there will be no collision with ground or other obstacle in the fall path.

6. PRE-USE CHECK:

- It is important to check before use, any dangers that may arise by the use of combinations of items of the equipment in which the safe function of any one item is affected by or interferes with the safe function of another.
- Carry out a pre-use check of the system, to ensure that it is in a serviceable condition and operates correctly before it is used.
- Ensure the compatibility of items of equipment when assembled into a system.

7. INSTALLATION:

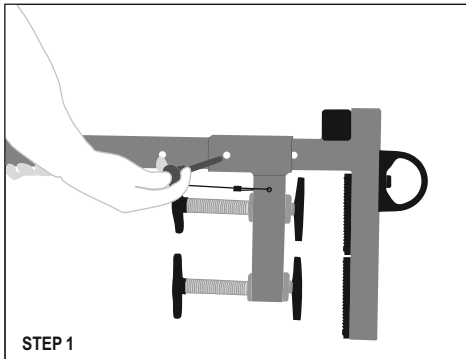

STEP 1

Unscrew the 2 clamping screws at the maximum and withdraw the locking pin.

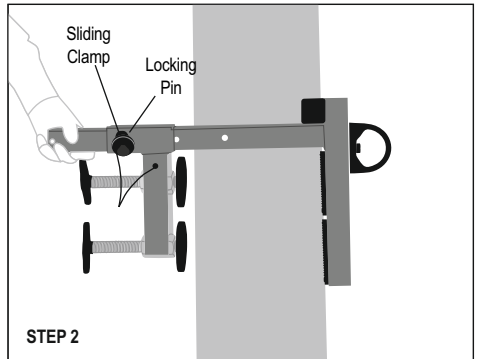

STEP 2

Install the parapet anchorage point on the wall, slide the clamping screws into the wall and insert the locking pin in the available hole closest to the wall.

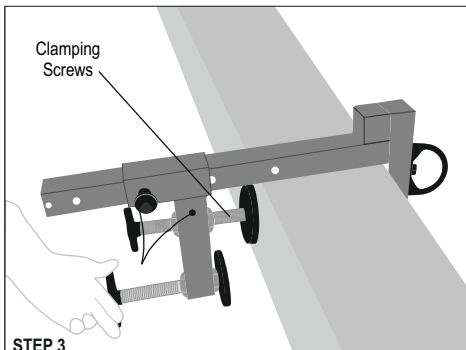

STEP 3

Tighten the 2 clamping screws on the wall, the pressure should be firm but not excessive, a hand tightening is sufficient.

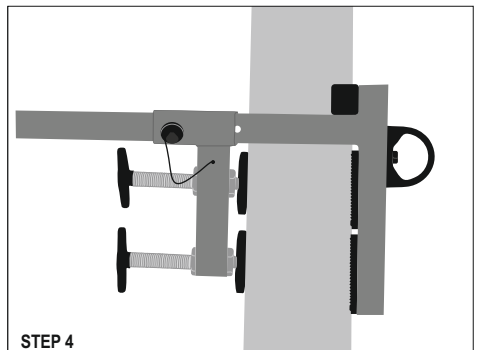

STEP 4

Check the stability of the whole and make a pressure in the sense in which the strength will be applied during the use to check that the system is properly fixed.

Note: It is recommended that the installation of this anchor point be supervised by a qualified person.

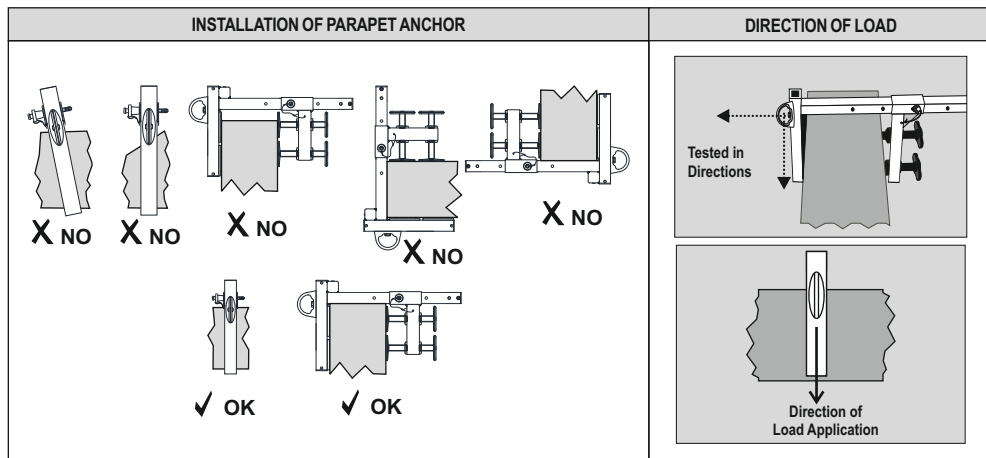

8. **ANCHORAGE STRENGTH:** Ensure that the structure on to which the anchor is fitted is strong enough to withstand a load of 12 kN.

9. **LIMITATIONS:**

- It should be the Personal property of its user.
- it should not be used in highly acidic or basic environments.
- The anchor has been tested to EN 795 : 2012 Type B and is appropriate only for single person use with an energy absorber as per EN 355:2002.
- Ensure that the Anchor is installed directly above the user's head.
- Ensure that the equipment is compatible with other items when assembled into a system.
- It is essential to verify the free space required beneath the user at work place before each occasion of use so that in case of a fall there will be no collision with ground or other obstacle in the fall path.
- It is essential for the safety of user that if the product is resold outside the original country of destination, the reseller shall provided instruction for use, for maintenance, for periodic examination and for repair in the language of the country in which product in to be used.
- When Anchor device is used as part of a fall arrest system, the user shall be equipped with a means of limiting the maximum dynamic forces exerted on the user during the arrest of a fall to a maximum of 6 kN.
- Following conditions may be hazardous & may affect the performance of Anchor -
 - Extreme temperature.
 - Trailing or looping of Lanyards over sharp edges.
 - Extreme acidic or basic environments.
 - Abrasive or sharp edge structures which can damage the equipment.
 - Chemical Reagents.
 - Climatic exposure.
 - Pendulum fall

10. **COMPATIBILITY:** To optimise protection, in some instance it may be necessary to use the anchor with suitable ppe such as boots/ gloves/ helmet/ ear defenders. In this case, before carrying out the risk-related activity, consult your supplier to ensure that all your protective products are compatible and suitable for your application.

11. **REPAIR:** If the product becomes damaged, it will NOT provide the optimum level of protection, and therefore should be immediately removed from service. Never use the damaged product. Repair is permitted, provided that it is either done by the manufacturer or a competent repair centre or individual approved by the manufacturer.

12. **WITHDRAWAL FROM USE:** If the system has been used to arrest a fall, it should be removed from service and returned to the manufacturer or a competent repair centre for servicing and re test.

13. **CLEANING:** In case of minor soiling, wipe the anchor with cotton cloth or a soft brush. Do not use any abrasive material. For intensive cleaning wash the anchor in water at a temperature between 30°C to 60°C by using a neutral detergent (pH 7). The washing temperature should not exceed 60°C. Do not use acid or basic detergents.
14. **STORAGE AND TRANSPORT:** When not in use, store the anchor in a well-ventilated area away from heavily acidic or basic environment. Never place heavy items on top of it. Also ensure that it is stored away from chemically hazardous environment preferably storage should be in dry environment.
15. **WARNING:**
- Do not make any alterations or additions to the equipment without the manufacturer's prior written consent and that any repair shall only be carried out by personnel trained by the manufacturer & duly authorized by him.
 - The equipment shall not be used outside its limitation, or for any purpose other than that for which it is intended.
 - It is important to conduct regular periodic examination of the product because the safety of the user depends upon the continued efficiency and durability of the product.
 - The periodic examination should be conducted by the competent person and strictly in accordance with the manufacturer's procedures.
 - The frequency of examination should be at least once in a year however it can be more than once if legislation requires, or frequency of use is high or environmental conditions have an adverse effect on it eg. excessive rain, sea side environment, excessive heat etc.
 - Ensure that all markings on the product are legible and readable.

MARKING



The Anchor is marked with:

- (i) The CE mark showing that the product meets the requirements of the PPE Regulation EU2016/425
- (ii) Identification of the manufacturer
- (iii) Type or product code
- (iv) Date of manufacturing
- (v) UID for traceability
- (vi) Norm Reference
- (vii) Minimum breaking strength
- (viii) Read the instruction before Use

LIFESPAN: The estimated product Lifespan is 10 years from the date of manufacture. The following factors can reduce the Lifespan of the product: intense use, contact with chemical substances, specially aggressive environments, extreme temperature exposure, UV exposure, abrasions, cuts, violent impacts, bad use or maintenance.

DISCLAIMER: Prior to use, the end user must read and understand the manufacturer's instructions supplied with this product at the time of shipment and seek training from their employer's trained personnel on the proper usage of the product. Manufacturer is not liable or responsible for any loss, damage or injury caused or incurred by any person on grounds of improper usage or installation of this product.

EQUIPMENT RECORD				
Product				
Model & type/identification		Trade Name	Identification number	
Manufacturer		Address	Tel, email into use	
Year of manufacture		Purchase Date	Date first put into use	
Other relevant information (eg. document number)				
PERIODIC EXAMINATION AND REPAIR HISTORY				
Date	Reason for entry (periodic examination or repair)	Defects noted, repairs carried out and other relevant information	Name and signature of competent person	Periodic examination next due date

Certification Body :

SATRA Technology Europe Ltd, Bracetown Business Park, Clonee, Dublin D15 YN2P Ireland (Notified Body 2777)

Ongoing Assessment Body:

SGS Fimko Oy, Takomotie 8, FI-00380 Helsinki, Finland (Notified Body 0598)

For EU Declaration, please visit <https://kstrong.com/asia/eu-declaration-form/>



150 N. Radnor Chester Road Suite F200
Radnor, Pennsylvania 19087 United States
Contact number : 1-833-KSTRONG

USA

South America

ASIA
